

Exam 1, Fall 2000

1. (13 points) Below is a diagram of a bacterium.
Is this a gram-negative or a gram-positive organism? (circle one)
Label the indicated parts.

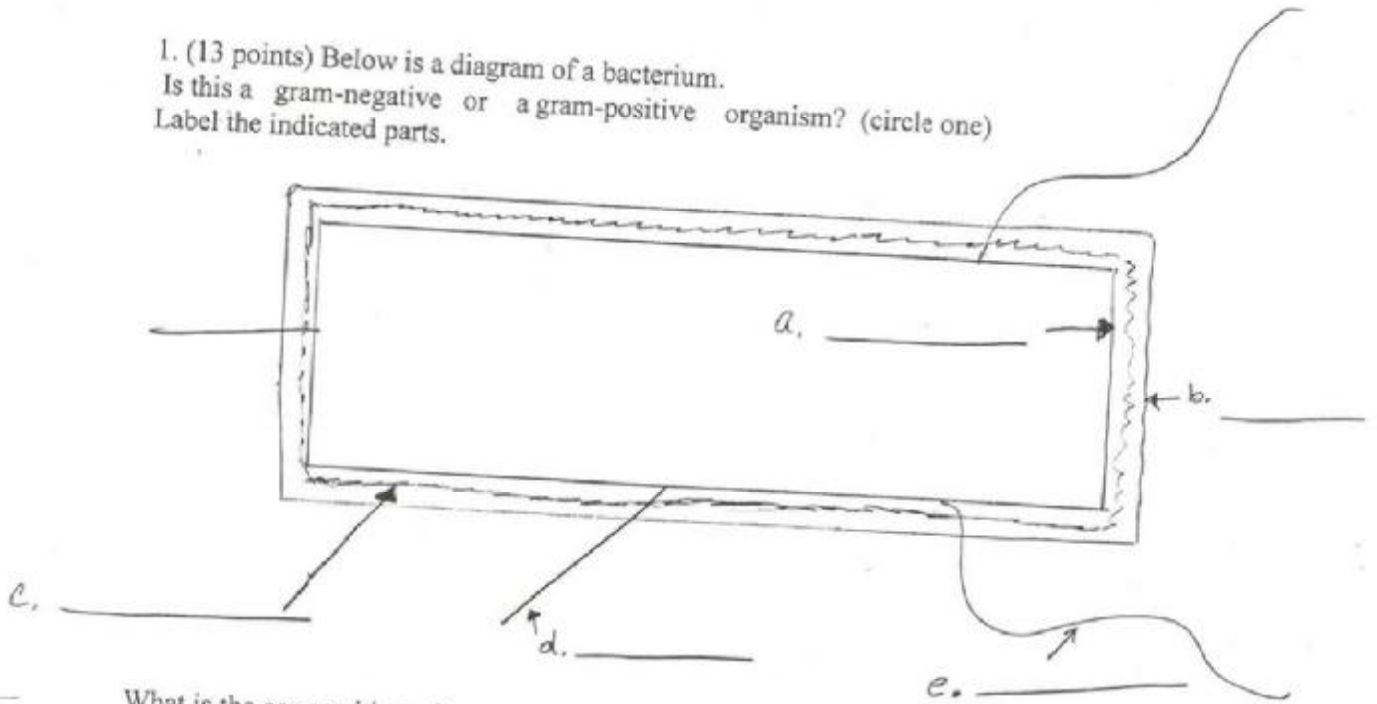

What is the composition of

- a. _____
- b. _____
- c. _____
- d. _____
- e. _____

If this bacterium were of the other type with respect to the Gram stain, what would be 2 major differences in the cell structure?

- 1. _____
- 2. _____

2. (6 points) You have isolated a bacterium from nature which can use a variety of energy sources for growth. Rank the following compounds used as an energy source under the conditions stated from that which will give the most energy (1) to the least energy(4).
 glucose-anaerobic, H₂S-aerobic, methanol-aerobic, Fe⁺²-aerobic

1. _____
2. _____
3. _____
4. _____

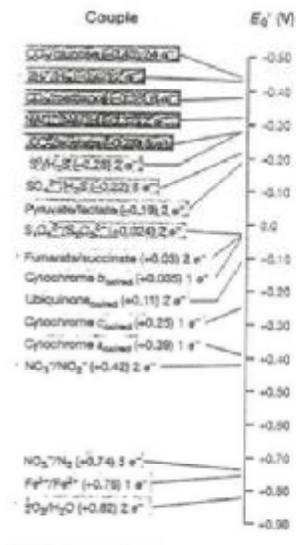

3. (10 points) Given the following pieces draw a diagram on the line below of a bacterial operon containing 2 genes, A and B, which are required for the metabolism of a sugar energy source. The operon is regulated by a repressor and an inducer. You may use any piece more than once and not all pieces need to be used. (This question will be graded by subtracting for each error).

ATG
 AAAAAAAAAA
 stop codon
 inducer binding site

promoter
 GGGGGGGG
 repressor binding site
 attenuator

ORF
 rbs(GGAGG)
 stem loop
 origin of replication

4. (9 points) Maltose is a sugar and the expression of maltase (the enzyme which breaks maltose down into glucose is regulated by an activator). Fill in the following table with respect to the expression of the genes and the ability of the bacterium carrying the genes to grow in minimal medium with maltose (use +, and - to fill in the table).

bacterial genotype	expression of <i>malA</i> in the presence of maltose	expression of <i>malA</i> in the absence of maltose	ability of the bacteria to grow on maltose
wild type			
$\frac{paA^+pT^-paF^+G^+K^+B^+}{paA^-pT^+paF^+G^+K^+B^-}$			
$\frac{p^-aA^+pT^-p^-aF^+G^+K^+B^+}{paA^+pT^+paF^+G^+K^+B^+}$			

malA=maltase, *malT*=activator, *malFGK* and *lamB* =transport genes, *p*=promoter, *a*=activator binding site

5. (9 points) Label the stages of a bacterial growth curve in liquid medium shown below (please print your answer plainly).

- a. _____
 b. _____
 c. _____
 d. _____

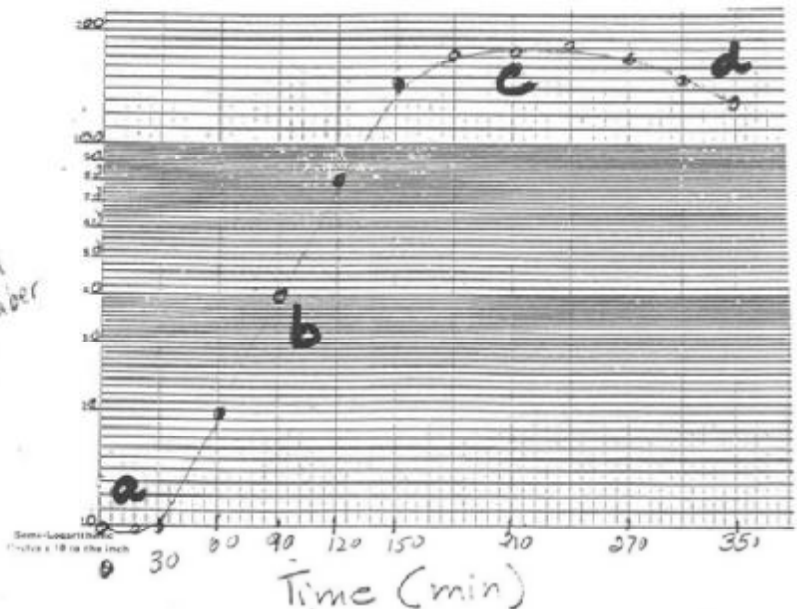

What is the doubling time of these cells during phase b? _____

Name three different environmental factors which affect bacterial growth.

1. _____
2. _____
3. _____

6. (11 points) Arginine is an amino acid. Fill in the following table using +, +/-, and - with respect to the expression of the genes involved in the biosynthesis of arginine.

bacterial genotype	expression of <i>argE</i> in the presence of arginine	expression of <i>argE</i> in the absence of arginine
wild type		
ΔR , p_{aECBH}	XXXXXXXXXXXXXXXX	
ΔR , $p_{\Delta aECBH}$	XXXXXXXXXXXXXXXX	
ΔR , p_{Δ} region 3 of the attenuator <i>ECBH</i>	XXXXXXXXXXXXXXXX	
ΔR , p_{aECBH} , mutation of arg t-RNA synthetase so that it puts trp on arg-t-RNA bacteria grown in trp	XXXXXXXXXXXXXXXX	
R , p_{trp} $aECBH$ bacteria grown in the presence of trp		

argR=repressor gene, a=attenuator, Δ =deletion, *argECBH*=genes for biosynthetic enzymes for arginine p=arg promoter, p_{trp} =trp promoter

7. (3 points) Cellulose is the major carbohydrate of the plant cell wall; it is made of repeating glucose molecules. Cellulase is an enzyme capable of breaking down the plant cell wall

- Can cellulase break down the bacterial cell wall? yes or no (circle one)
- Why or why not?

8. (7 points) In what stage of T4 infection do the following events occur? (Indicate your answer by placing a check mark in the appropriate column).

event	early	middle	late
phage DNA transcription			
tail fiber production			
nuclease transcription			
phage head protein mRNA translated			
new σ factor gene transcribed			

Which of the models shown below represents the genetic material found in a T4 phage? (circle one)

agcucuu
tggagaa
|
CH₃

agtcca
tcagct
|
CH₃

agcaggtt
|
CH₃

gaguaguu

9. (8 points) Below is a diagram of the gene products involved in regulating chemotaxis in *E. coli*. Indicate phenotypes for chemotaxis for mutants in each of the following genes:

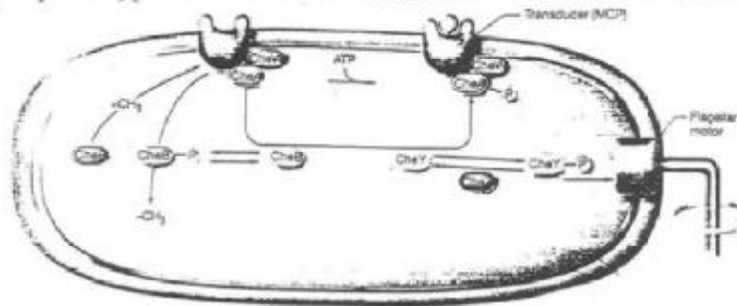

mutant gene	phenotype of mutant
<i>cheY</i> ⁻	
<i>cheZ</i> ⁻	
<i>cheB</i> ⁻	
MCP with a decreased binding affinity	

10 (8 points) How would you isolate an *E. coli* mutant which was altered in chemotaxis genes (the mutant should still be motile)?

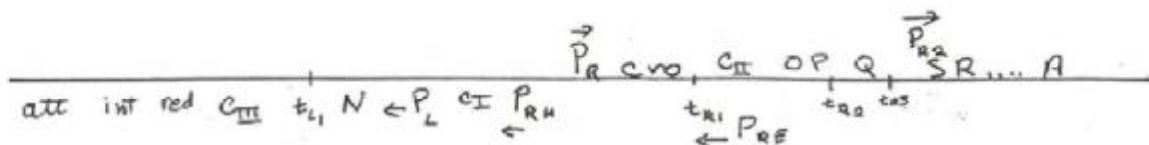

11. (8 points) Fill in the following table with respect to the phenotype of various mutants in phage λ . Plaques can be clear, cloudy, or none. Mutants can cause plaques to become cloudier or clearer than wild type.

λ phage genotype	plaques on <i>E. coli</i> K12 (-)	plaques on <i>E. coli</i> K12 (λ)
<i>CII</i> mutant		
mutant with Q deleted		
mutant with P_{tp} substituted for P_R with the infection done in medium containing tryptophan		
mutant with P_{tp} substituted for P_{RE} with the infection done in medium lacking tryptophan		

12. (8 points) Polio is a ssRNA virus (+ strand). How can it make multiple proteins when it infects a human cell?